

**Mashinasozlik yo'nalishi uchun yakuniy DAK imtixon uchun topshiriqlar.
(CNC Frezalash va CNC Tokarniy)**

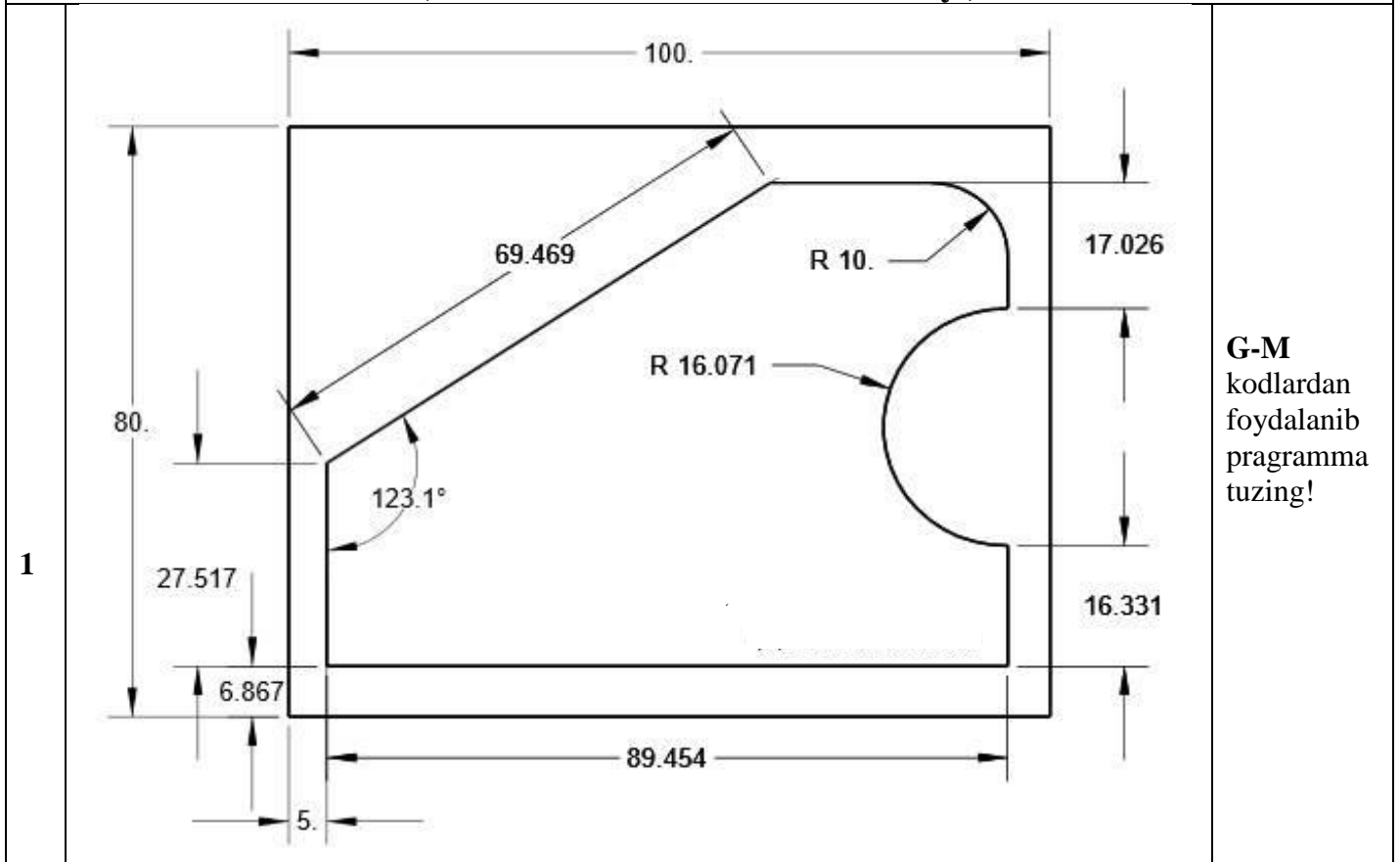

G-M
kodlardan
foydalanib
programma
tuzing!

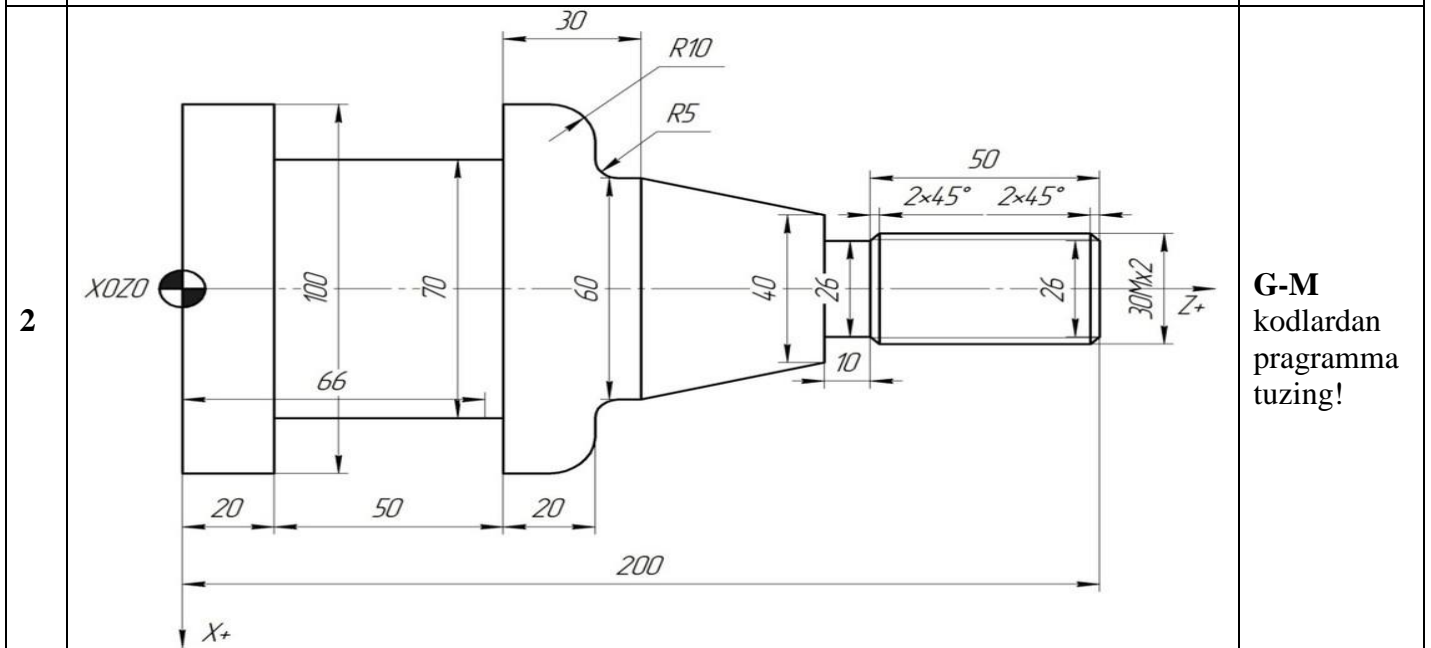



G-M
kodlardan
programma
tuzing!

№	Kamissiya azosining FISH	CNC Frezalash bo'yicha olgan bahosi	CNC Tokarlik bo'yicha olgan bahosi	Imzo
1				
2				
3				
Jami:				

Talabanning FIO' _____ imzo _____

Mashinasozlik yo'nalishi uchun yakuniy imtixon uchun topshiriqlar.(Frezalash,Tokarniy mashinalar uchun topshiriqlar)

1			<p>Mashinaning qisimlarini tanishtiring!</p>
----------	---	--	--

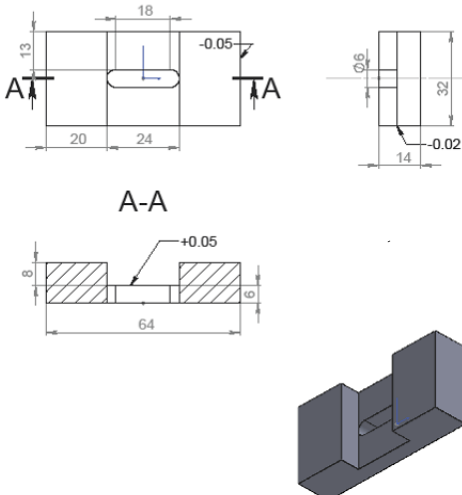
2		<p>Frezerniy mashinada topshiriqni bajarib ko'rsating!</p>
----------	--	--

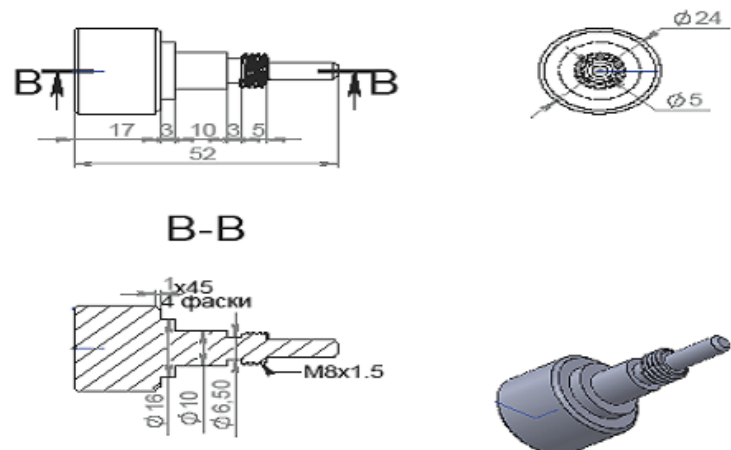
3		<p>Tokarniy mashinada topshiriqni bajarib ko'rsating!</p>
----------	--	---

№	Komissiya azosining FISH	Frezalash bo'yicha olgan bahosi	Tokarlik bo'yicha olgan bahosi	Imzo
1				
2				
3				
Jami:				

Talabning FIO' _____ imzo _____

Mashinasozlik yo'nalishi uchun yakuniy imtixon uchun topshiriqlar. (Solidworks CAD dasturi uchun topshiriqlar)

1

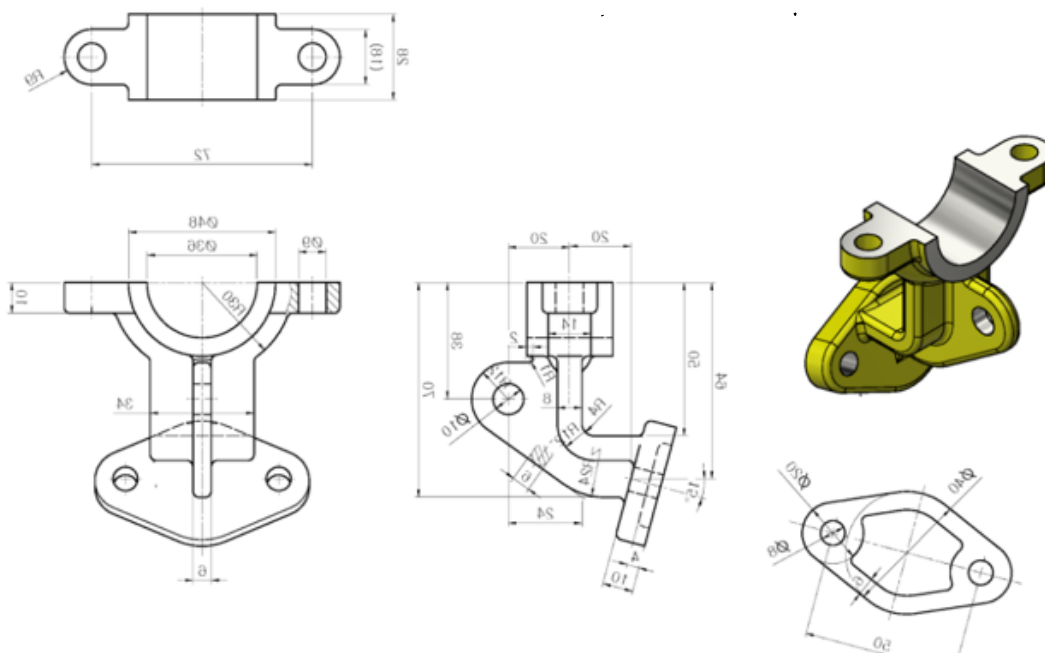

Chizmani chizing va CAM dasturida G- kodga o'tkazing !

2

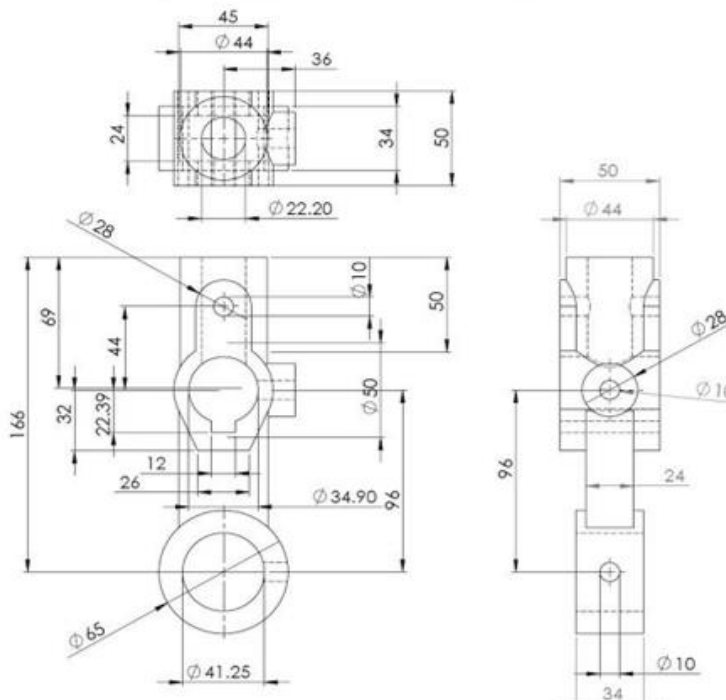
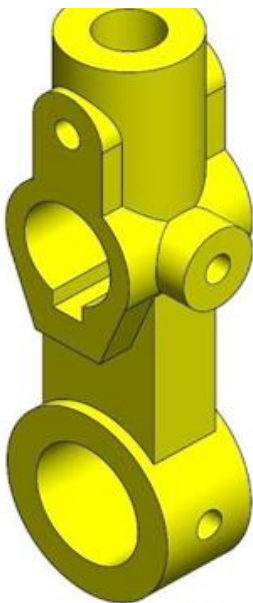

Chizmani chizing va CAM dasturida G- kodga o'tkazing !

№	Kamissiya azosining FISH	Birinchi chizma	Ikkinchi chizma	Imzo
1				
2				
3				
Jami:				

Talabanning FIO' _____ imzo _____